

Exemple de terminaison pour manille
Exemple of ending

Swivel weight / poids emerillon: 1420g

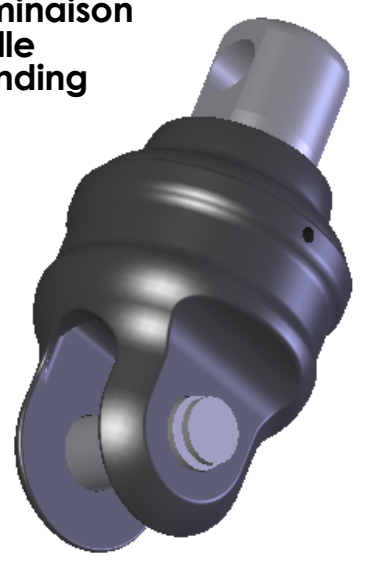

Drum weight / poids tourelle: 2200g

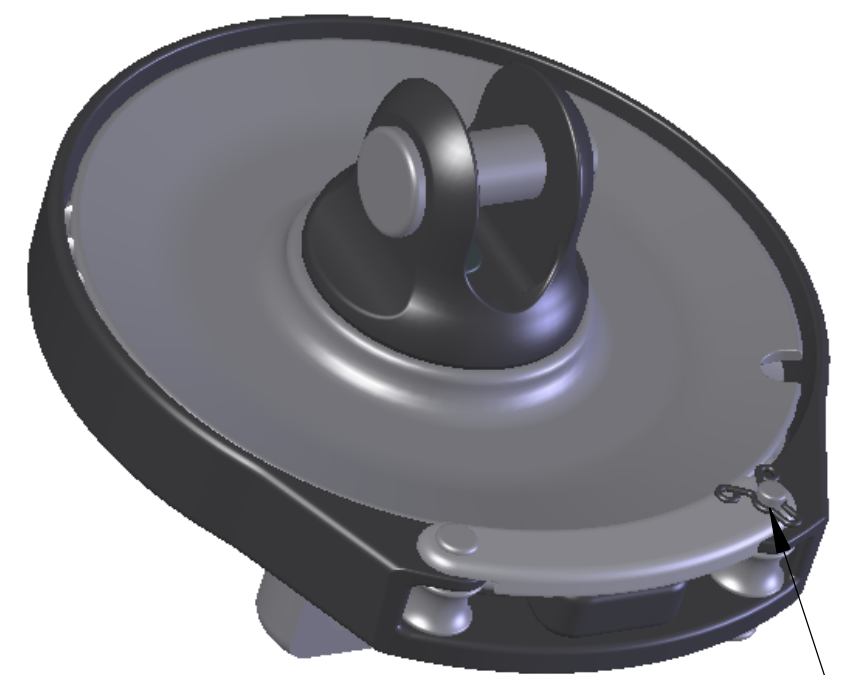

Dimension depend to the thimble size

Système de mise en place rapide du cordage de manoeuvre (breveté)
Fast engagement of the loop line (patented)

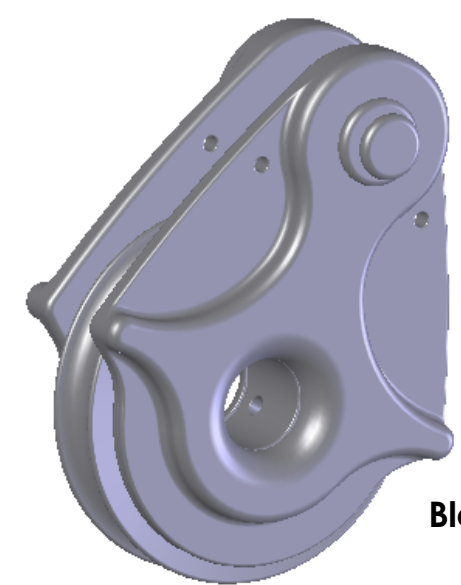

Block weight / poids poulie: 915g

Charge de travail maxi: 12000Kg / Breaking 24T

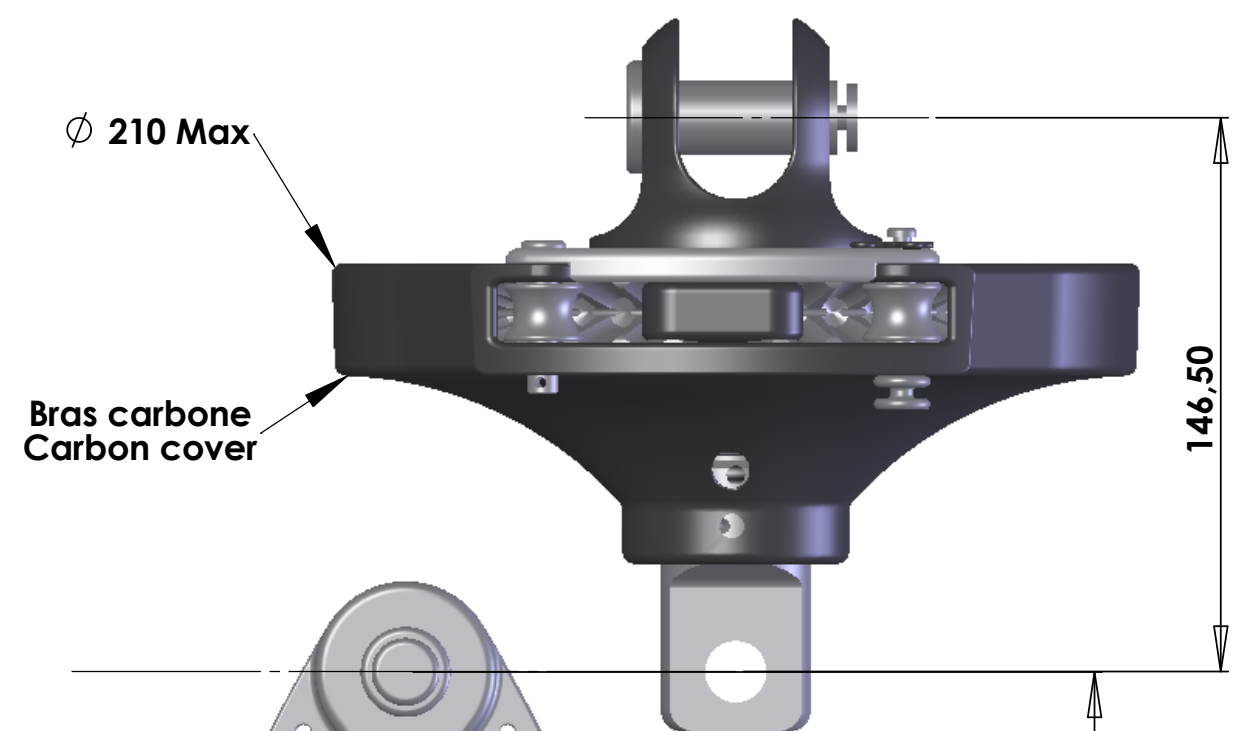

Bras carbone
Carbon cover

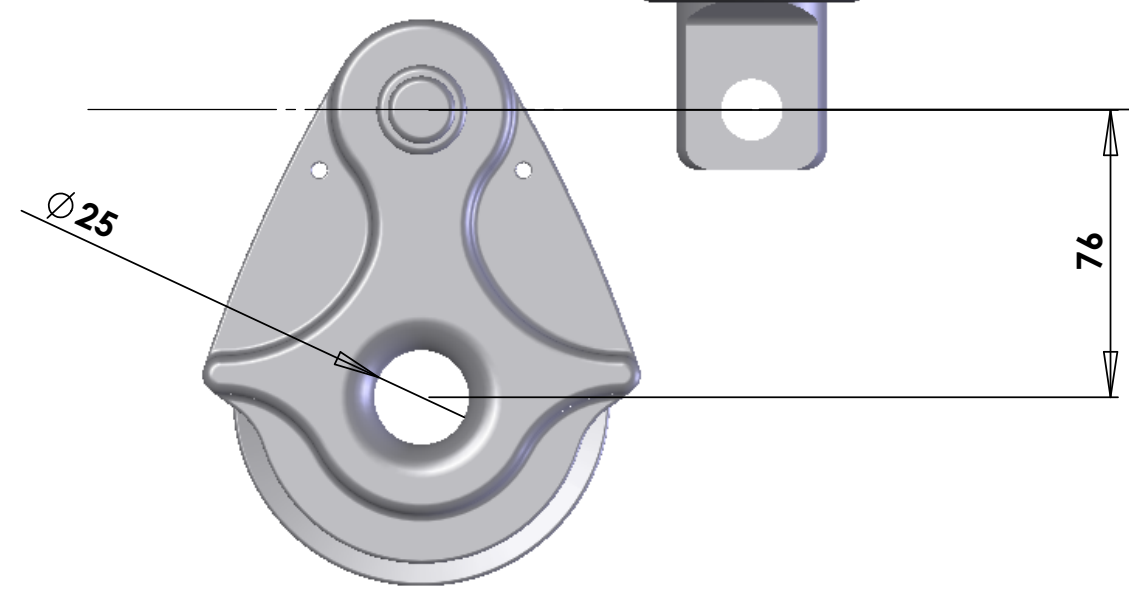

DATE		MODIFICATIONS APORTEES			NOM	VISA	IND.
MATIERE ET ETAT		TOLERANCE GENERALE		EVOLUTION DU DOCUMENT			
TRAITEMENT; CARACTERISTIQUES MECANQUES		ETAT DE SURFACE GENERAL		DESS. PAR Le: M.C	MASSE	ECHELLE	
FINITION		PROTECTION		FOLIO			1/2
ATTACHEMENT		MATERIEL					
DESIGNATION		PRESENTATION		KF12			
CODE PRODUIT	K	CODE ENSEMBLE ou SOUS ENSEMBLE	K	CODE PIECE			FORMAT A3